

# MSQ30N10D

## Dual N-Channel 30-V (D-S) MOSFET

### Description

The device is the highest performance trench N-ch MOSFETs with extreme high cell density, which provide excellent  $R_{DS(ON)}$  and gate charge for most of the synchronous buck converter applications.

The device meets the RoHS and Green Product requirement, 100% EAS guaranteed with full function reliability approved.

### Features

- $R_{DS(ON)} = 14m\Omega @ V_{GS} = 10V$
- Super Low Gate Charge
- Excellent  $CdV/dt$  effect decline
- 100% EAS Guaranteed
- Green Device Available

### Typical Applications

- MB / VGA / Vcore
- POL Applications
- SMPS 2<sup>nd</sup> SR

Package type : SOP-8

### Packing & Order Information

3,000/Reel

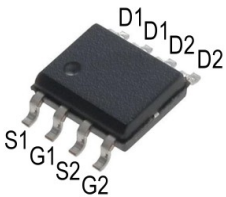

RoHS Compliant

### Graphic Symbol

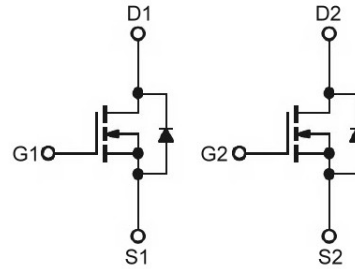

### Package Dimension

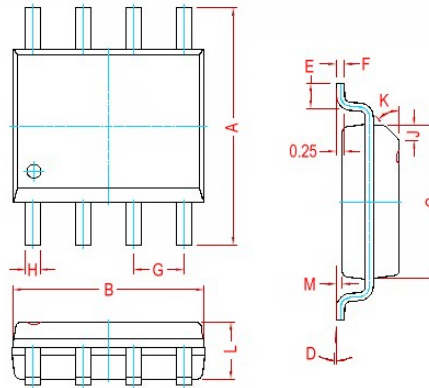

REF.	Millimeter		REF.	Millimeter	
	Min.	Max.		Min.	Max.
A	5.80	6.20	M	0.10	0.25
B	4.80	5.00	H	0.35	0.51
C	3.80	4.00	L	1.35	1.75
D	0°	8°	J	0.40 Ref.	
E	0.40	0.90	K	45° Ref.	
F	0.19	0.26	G	1.27 Typ.	

### Marking

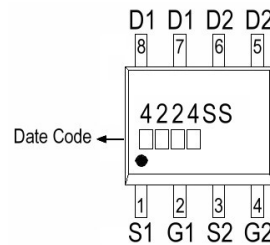

## MSQ30N10D

### Dual N-Channel 30-V (D-S) MOSFET

#### MAXIMUM RATINGS AND ELECTRICAL CHARACTERISTICS

##### Absolute Maximum Ratings

Symbol	Parameter	Value	Units
$V_{DS}$	Drain-Source Voltage	30	V
$V_{GS}$	Gate-Source Voltage	$\pm 20$	V
$I_D$	Continuous Drain Current <sup>1</sup> ( $T_A = 25^\circ\text{C}$ )	10	A
	Continuous Drain Current <sup>1</sup> ( $T_A = 70^\circ\text{C}$ )	8	A
$I_{DM}$	Pulsed Drain Current <sup>1,2</sup>	30	A
$I_{AS}$	Single Pulse Avalanche Current, $L = 0.1\text{mH}^3$	21	A
$E_{AS}$	Single Pulse Avalanche Energy, $L = 0.1\text{mH}^3$	22	mJ
$P_D$	Power Dissipation <sup>4</sup> ( $T_A = 25^\circ\text{C}$ )	2	W
$T_J/T_{STG}$	Operating Junction and Storage Temperature	-55 to +150	$^\circ\text{C}$

##### Thermal Resistance Ratings

Symbol	Parameter	Maximum	Units
$R_{\theta JA}$	Maximum Junction-to-Ambient <sup>1</sup>	62.5	$^\circ\text{C/W}$

##### Electrical Characteristics ( $T_J = 25^\circ\text{C}$ unless otherwise specified)

Symbol	Parameter	Test Conditions	Min.	Typ.	Max.	Units
$V_{GS(th)}$	Gate Threshold Voltage	$V_{DS} = V_{GS}, I_D = 250\mu\text{A}$	1.0	-	3.0	V
$BV_{DSS}$	Drain-Source Breakdown Voltage	$V_{GS} = 0\text{V}, I_D = 250\mu\text{A}$	30	-	-	V
$g_{fs}$	Forward Transconductance	$V_{DS} = 5\text{V}, I_D = 10\text{A}$	-	6	-	S
$I_{GSS}$	Gate-Source Leakage Current	$V_{DS} = 0\text{V}, V_{GS} = \pm 20\text{V}$	-	-	$\pm 100$	nA
$I_{DSS}$	Drain-Source Leakage Current	$V_{DS} = 30\text{V}, V_{GS} = 0\text{V}, T_J = 25^\circ\text{C}$	-	-	1	$\mu\text{A}$
		$V_{DS} = 24\text{V}, V_{GS} = 0\text{V}, T_J = 70^\circ\text{C}$	-	-	25	$\mu\text{A}$
$R_{DS(on)}$	Static Drain-Source On-Resistance <sup>2</sup>	$V_{GS} = 10\text{V}, I_D = 10\text{A}$	-	9	14	$\text{m}\Omega$
		$V_{GS} = 4.5\text{V}, I_D = 7\text{A}$	-	12	20	$\text{m}\Omega$
$E_{AS}$	Single Pulse Avalanche Energy <sup>5</sup>	$V_{DD} = 25\text{V}, L = 0.1\text{mH}, I_{AS} = 10\text{A}$	5	-	-	mJ
$V_{SD}$	Diode Forward Voltage <sup>2</sup>	$I_S = 10\text{A}, V_{GS} = 0\text{V}, T_J = 25^\circ\text{C}$	-	-	1.2	V
$I_S$	Continuous Source Current <sup>1,6</sup>	$V_G = V_D = 0\text{V}, \text{Force Current}$	-	-	10	A
$I_{SM}$	Pulsed Source Current <sup>2,6</sup>		-	-	30	

## MSQ30N10D

### Dual N-Channel 30-V (D-S) MOSFET

Dynamic						
Symbol	Parameter	Test Conditions	Min.	Typ.	Max.	Units
Q <sub>g</sub>	Total Gate Charge <sup>2</sup>	V <sub>DS</sub> = 15V	--	12.6	--	nC
Q <sub>gs</sub>	Gate-Source Charge	I <sub>D</sub> = 10A	--	4.2	--	
Q <sub>gd</sub>	Gate-Drain Charge	V <sub>GS</sub> = 4.5V	--	5.1	--	
t <sub>d(on)</sub>	Turn-On Delay Time <sup>2</sup>	V <sub>DS</sub> = 15V	--	6.2	--	ns
t <sub>r</sub>	Rise Time	I <sub>D</sub> = 10A	--	59	--	
t <sub>d(off)</sub>	Turn-Off Delay Time	V <sub>GS</sub> = 10V	--	27.6	--	
t <sub>f</sub>	Fall Time	R <sub>G</sub> = 3.3Ω	--	8.4	--	
C <sub>iss</sub>	Input Capacitance	V <sub>DS</sub> = 15V	--	1317	--	pF
C <sub>oss</sub>	Output Capacitance	V <sub>GS</sub> = 0V	--	163	--	
C <sub>rss</sub>	Reverse Transfer Capacitance	f = 1.0MHz	--	131	--	
R <sub>g</sub>	Gate Resistance	V <sub>GS</sub> = V <sub>DS</sub> = 0V, f = 1.0MHz	--	2.2	--	Ω

#### Notes

1. The data tested by surface mounted on a 1 inch<sup>2</sup> FR-4 board with 2OZ copper.
2. The data tested by pulsed, pulse width ≤ 300us, duty cycle ≤ 2%.
3. The EAS data shows maximum rating. The test condition is V<sub>DD</sub>=25V, V<sub>GS</sub>=10V, L=0.1mH, I<sub>AS</sub>=21A.
4. The power dissipation is limited by 150°C junction temperature.
5. The Min. value is 100% EAS tested guarantee.

The data is theoretically the same as I<sub>D</sub> and I<sub>DM</sub>, in real applications, should be limited by total power dissipation.

# MSQ30N10D

## Dual N-Channel 30-V (D-S) MOSFET

- Typical Electrical Characteristics

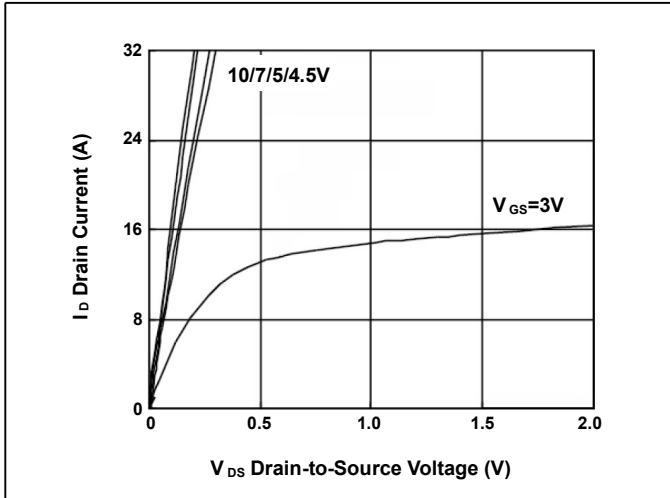

**FIG.1-Typical Output Characteristics**

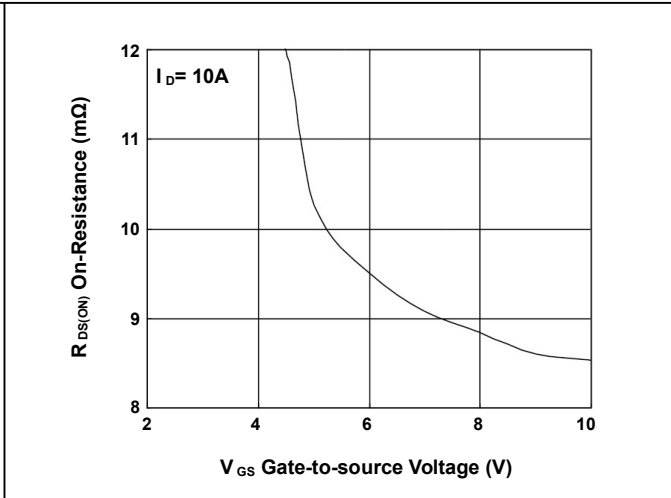

**FIG.2-On-Resistance vs. G-S Voltage**

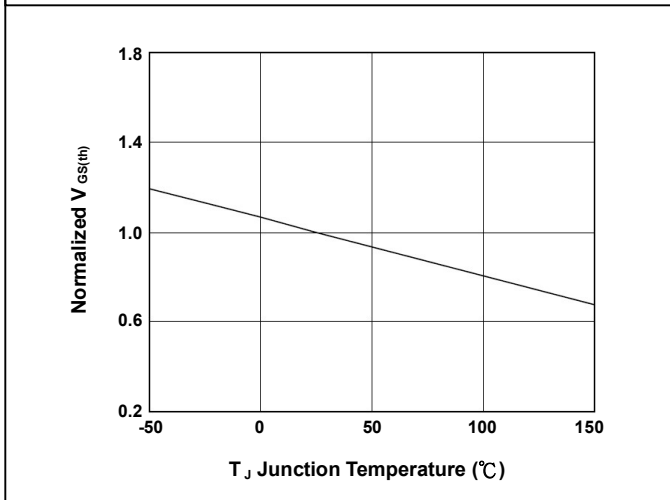

**FIG.3-Normalized  $V_{GS(th)}$  vs.  $T_J$**

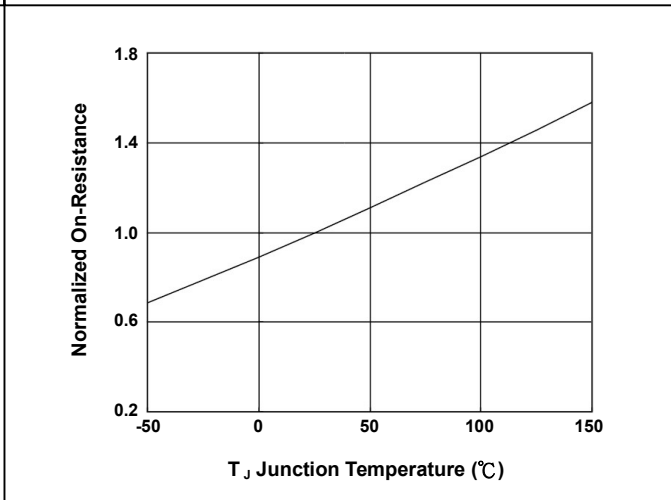

**FIG.4-Normalized  $R_{DS(on)}$  vs.  $T_J$**

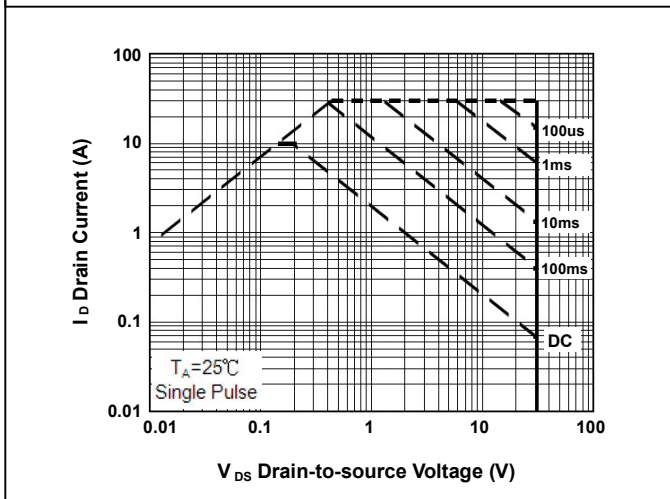

**FIG.5-Safe Operating Area**

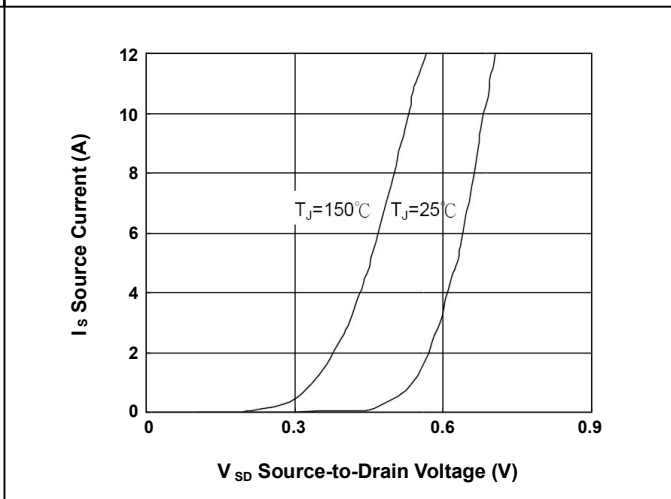

**FIG.6-Forward Characteristics of Reverse**

## MSQ30N10D

Dual N-Channel 30-V (D-S) MOSFET

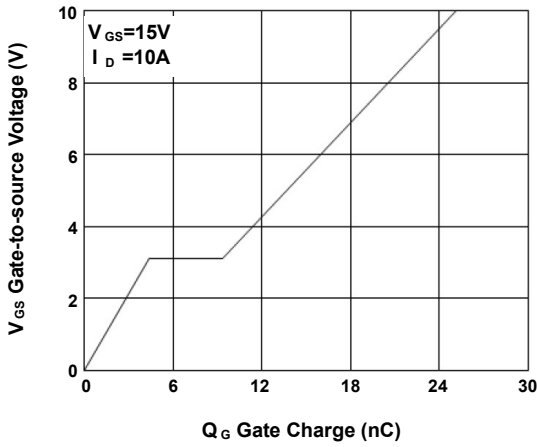

FIG.7-Gate Charge Characteristics

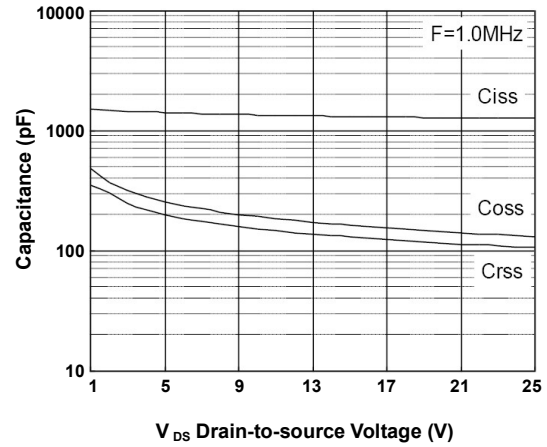

FIG.8-Capacitance Characteristics

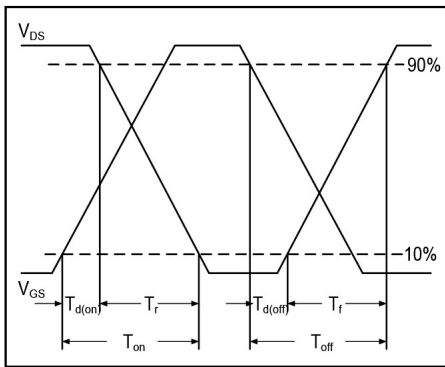

FIG.9-Switching Time Waveform

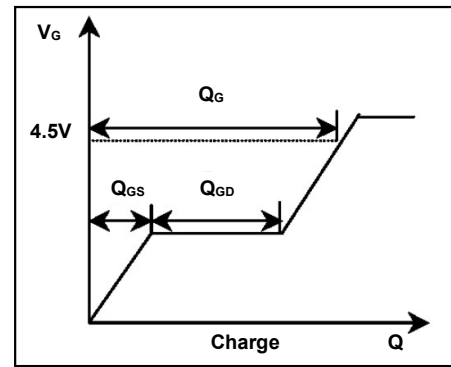

FIG.10-Gate Charge Waveform

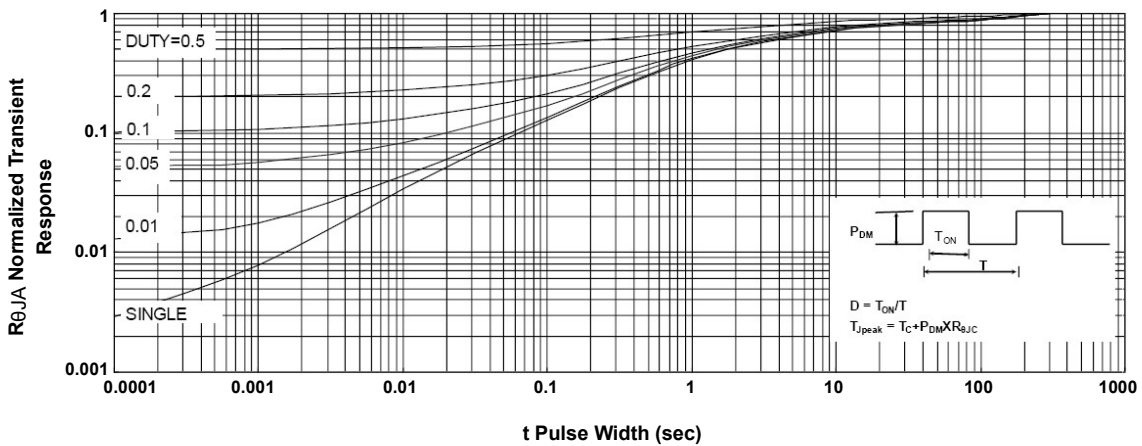

FIG.11-Normalized Maximum Transient Thermal Impedance

## MSQ30N10D

Dual N-Channel 30-V (D-S) MOSFET

### Disclaimer

ALL PRODUCT, PRODUCT SPECIFICATIONS AND DATA ARE SUBJECT TO CHANGE WITHOUT NOTICE TO IMPROVE RELIABILITY, FUNCTION OR DESIGN OR OTHERWISE.

Bruckewell Technology Inc., its affiliates, agents, and employees, and all persons acting on its or their behalf (collectively, "Bruckewell"), disclaim any and all liability for any errors, inaccuracies or incompleteness contained in any datasheet or in any other disclosure relating to any product.

Bruckewell makes no warranty, representation or guarantee regarding the suitability of the products for any particular purpose or the continuing production of any product. To the maximum extent permitted by applicable law, Bruckewell disclaims

- (i) Any and all liability arising out of the application or use of any product.
- (ii) Any and all liability, including without limitation special, consequential or incidental damages.
- (iii) Any and all implied warranties, including warranties of fitness for particular purpose, non-infringement and merchantability.

Statements regarding the suitability of products for certain types of applications are based on Bruckewell's knowledge of typical requirements that are often placed on Bruckewell products in generic applications.

Such statements are not binding statements about the suitability of products for a particular application. It is the customer's responsibility to validate that a particular product with the properties described in the product specification is suitable for use in a particular application. Parameters provided in datasheets and/or specifications may vary in different applications and performance may vary over time.

Product specifications do not expand or otherwise modify Bruckewell's terms and conditions of purchase, including but not limited to the warranty expressed therein.