

## SS32B-SS3100B

Surface Mount Schottky Barrier Rectifiers

REVERSE VOLTAGE: 20 - 100 V

### Features

- Guarding protection
- Low forward voltage
- Reverse energy tested
- High current capability
- Extremely low thermal resistance
- RoHS compliant package

### Mechanical Data

- Case: SMC Molded plastic
- Epoxy: UL 94V-0 rate flame retardant
- Lead: Lead Formed for Surface Mount
- Polarity: Color band denotes cathode end
- Mounting position: Any
- Weight: 0.093 grams

### Packing & Order Information

3,000/Reel

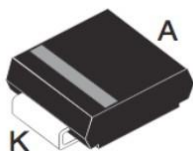

**RoHS**  
COMPLIANT

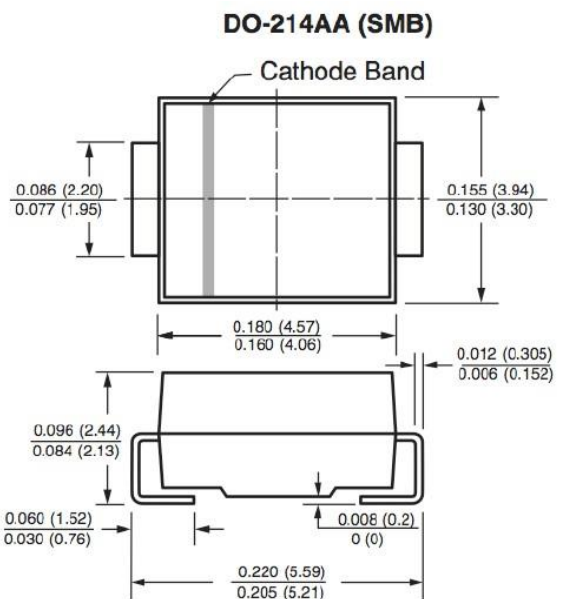

### Graphic symbol



### MAXIMUM RATINGS AND ELECTRICAL CHARACTERISTICS

Ratings at 25°C ambient temperature unless otherwise specified

		SS32B	SS33B	SS34B	SS35B	SS36B	SS38B	SS39B	SS3100B	Unit
Device marking code		SS32	SS33	SS34	SS35	SS36	SS38	SS39	SS3100	
Maximum repetitive peak reverse voltage	$V_{RRM}$	20	30	40	50	60	80	90	100	V
Maximum RMS voltage	$V_{RWS}$	14	21	28	35	42	56	63	70	V
Maximum DC blocking voltage	$V_{DC}$	20	30	40	50	60	80	90	100	V
Maximum average forward rectified current at $T_L=90^\circ\text{C}$	$I_{F(AV)}$	3.0								A

## SS32B-SS3100B

Surface Mount Schottky Barrier Rectifiers

REVERSE VOLTAGE: 20 - 100 V

Ratings at 25°C ambient temperature unless otherwise specified

		SS32B	SS33B	SS34B	SS35B	SS36B	SS38B	SS39B	SS3100B	Unit	
Device marking code		SS32	SS33	SS34	SS35	SS36	SS38	SS39	SS3100		
Peak forward surge current 8.3ms single half sine-wave	$I_{FSM}$	100								A	
Maximum instantaneous forward voltage at IFM=3.0A (NOTE1)	$V_F$	0.50		0.75		0.85				V	
Maximum DC reverse current TJ=25°C	$I_R$	0.5 20								mA	
Maximum thermal resistance	$R_{\theta Jc}$	10								° C/W	
Operating junction temperature range	$T_J$	-55 +125			-55 +150						°C
Storage temperature range	$T_{STG}$	-55 +150								°C	

Notes:

1.Pulse test: Pulse width 300us, duty cycle 1%

## SS32B-SS3100B

Surface Mount Schottky Barrier Rectifiers

REVERSE VOLTAGE: 20 - 100 V

### ■ RATING AND CHARACTERISTIC CURVES

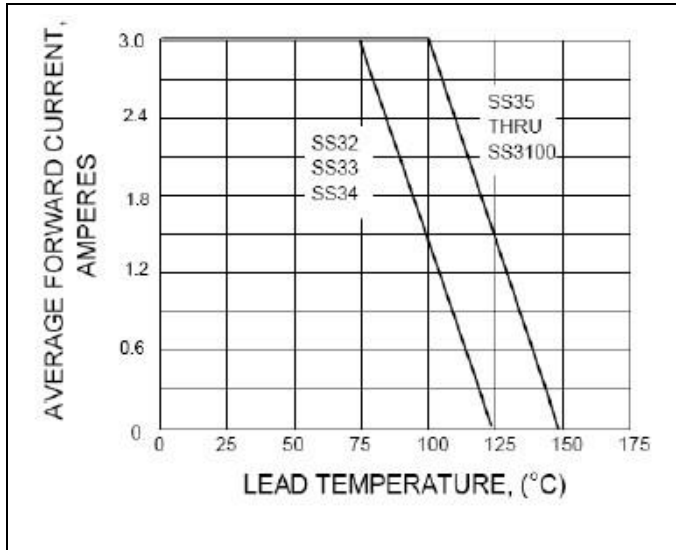

FIG.1-FORWARD CURRENT CURVE

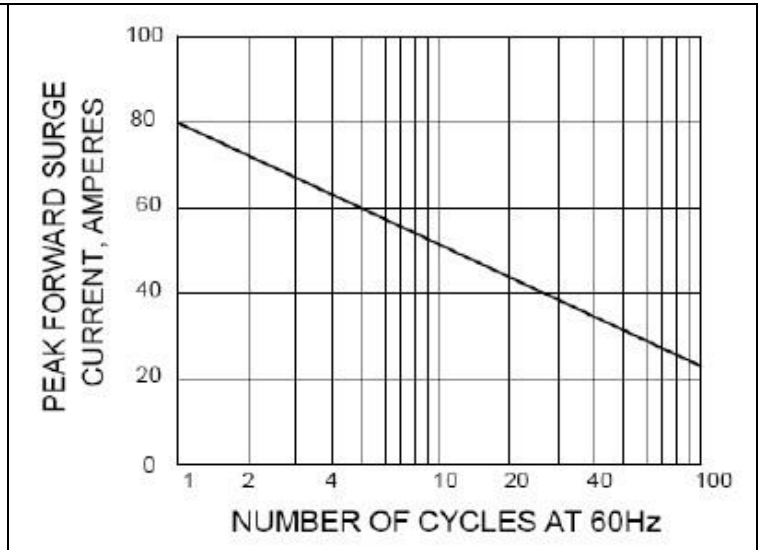

FIG.2-PEAK FORWARD SURGE CURRENT

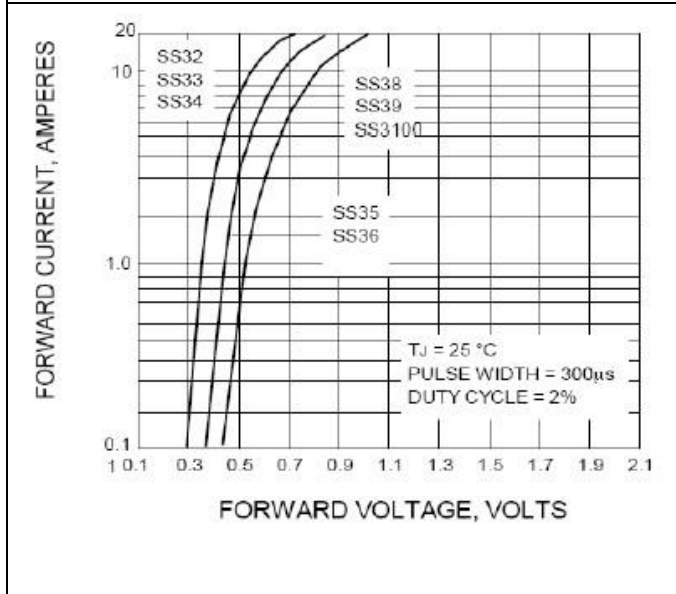

FIG.3-TYPICAL FORWARD CHARACTERISTICS

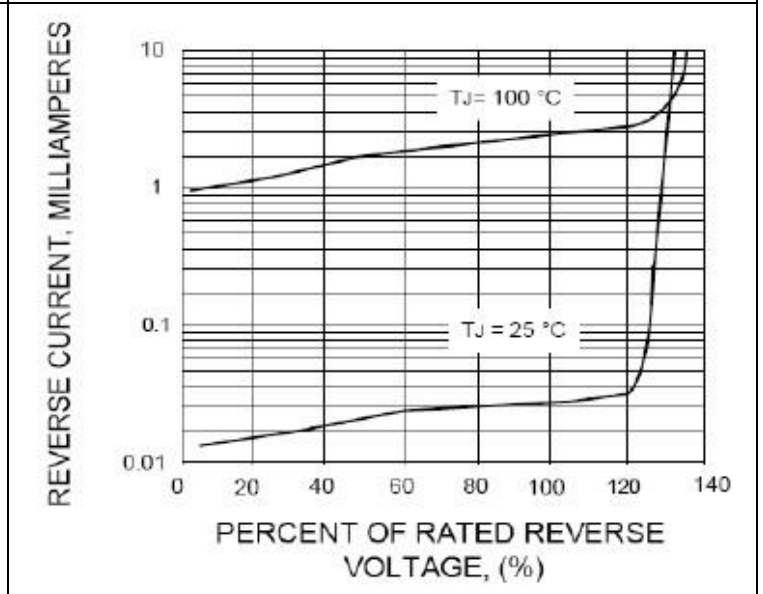

FIG.4-TYPICAL REVERSE CHARACTERISTICS

## SS32B-SS3100B

Surface Mount Schottky Barrier Rectifiers

REVERSE VOLTAGE: 20 - 100 V

### Disclaimer

ALL PRODUCT, PRODUCT SPECIFICATIONS AND DATA ARE SUBJECT TO CHANGE

WITHOUT NOTICE TO IMPROVE RELIABILITY, FUNCTION OR DESIGN OR OTHERWISE.

Bruckewell Technology Inc., its affiliates, agents, and employees, and all persons acting on its or their behalf (collectively, "Bruckewell"), disclaim any and all liability for any errors, inaccuracies or incompleteness contained in any datasheet or in any other disclosure relating to any product.

Bruckewell makes no warranty, representation or guarantee regarding the suitability of the products for any particular purpose or the continuing production of any product. To the maximum extent permitted by applicable law, Bruckewell disclaims

- (i) Any and all liability arising out of the application or use of any product.
- (ii) Any and all liability, including without limitation special, consequential or incidental damages.
- (iii) Any and all implied warranties, including warranties of fitness for particular purpose, non-infringement and merchantability.

Statements regarding the suitability of products for certain types of applications are based on Bruckewell's knowledge of typical requirements that are often placed on Bruckewell products in generic applications.

Such statements are not binding statements about the suitability of products for a particular application. It is the customer's responsibility to validate that a particular product with the properties described in the product specification is suitable for use in a particular application. Parameters provided in datasheets and/or specifications may vary in different applications and performance may vary over time.

Product specifications do not expand or otherwise modify Bruckewell's terms and conditions of purchase, including but not limited to the warranty expressed therein.